

1 2 3 4 5 6 7 8 9 10 11 12 13 14 15 16

A
B
C
D
E
F
G
H
I
J

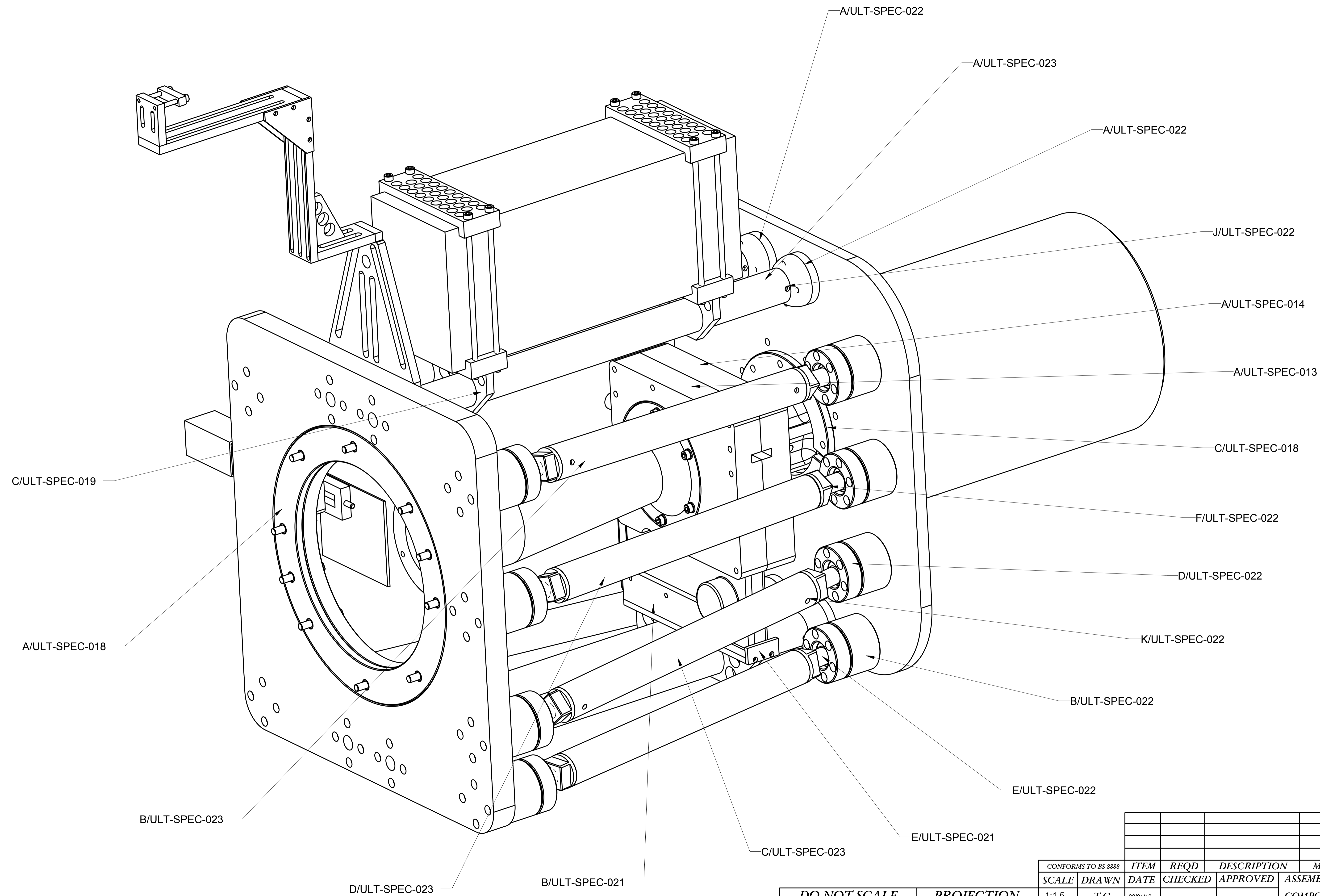

NOTE!
THIS DRAWING TO BE READ IN CONJUNCTION WITH DRAWING No'S
ULT-SPEC-029 "GENERAL ARRANGEMENT, ACCESS SIDE"
ULT-SPEC-031 "SECTION THROUGH GENERAL ARRANGEMENT"

DO NOT SCALE
PROJECTION
EXPLANATION OF NOTES,
SYMBOLS, DIMS: SEE BS 8888
GENERAL NOTES
DIMENSIONS mm
REMOVE ALL BURRS AND SHARP CORNERS
MAXIMUM CHAMFER 0.5 U.S.O
LINEAR DIMENSIONS +/- 0.1 U.S.O
ANGULAR DIMENSIONS +/- 0' 30" U.S.O
SURFACES 3.2 μ m U.S.O

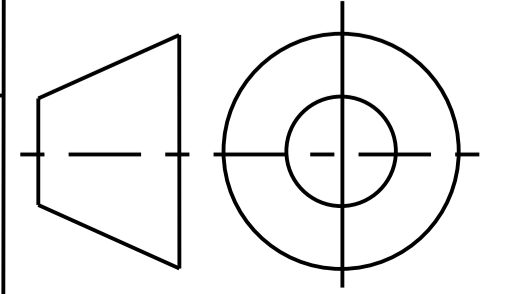

| CONFORMS TO BS 8888 | | ITEM | REQD | DESCRIPTION | MATERIAL |
|--|-------|----------|---------|-------------|------------|
| SCALE | DRAWN | DATE | CHECKED | APPROVED | ASSEMBLY # |
| 1:1.5 | T.G | 08/01/13 | | | COMPONENTS |
| AREA THAI NATIONAL TELESCOPE "THAILAND" | | | | | |
| DESCRIPTION GENERAL ARRANGEMENT OF STRUCTURE & OPTICS "NON ACCESS SIDE" | | | | | |
| THIS DRAWING IS STRICTLY CONFIDENTIAL. NOT FOR THIRD PARTY DISTRIBUTION. | | | | | |
| DRAWING NUMBER | | | | | REV |
| ULT-SPEC-030 | | | | | A |

1 2 3 4 5 6 7 8 9 10

