

ZABER LINEAR ACTUATOR
0.55 kg

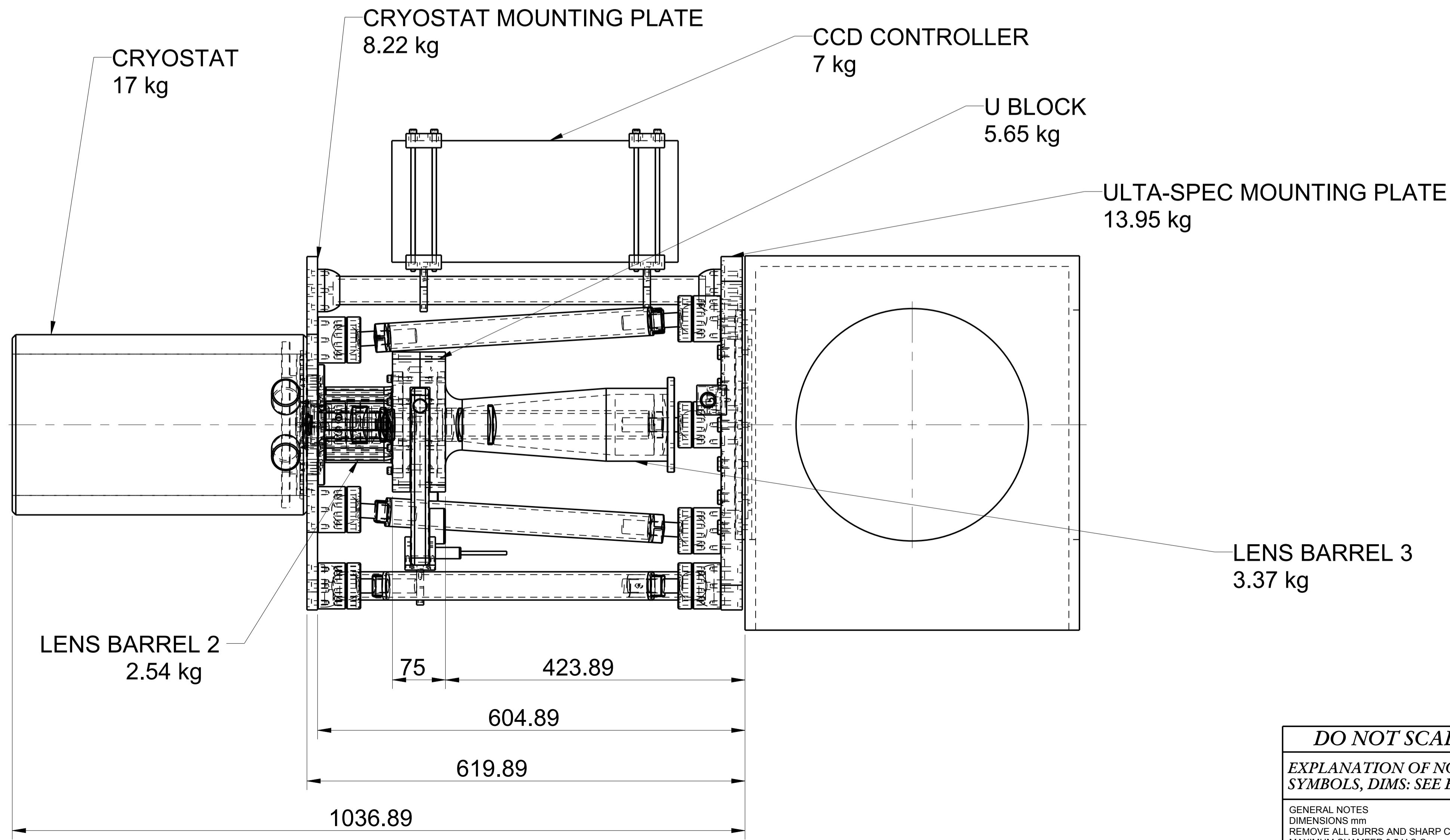
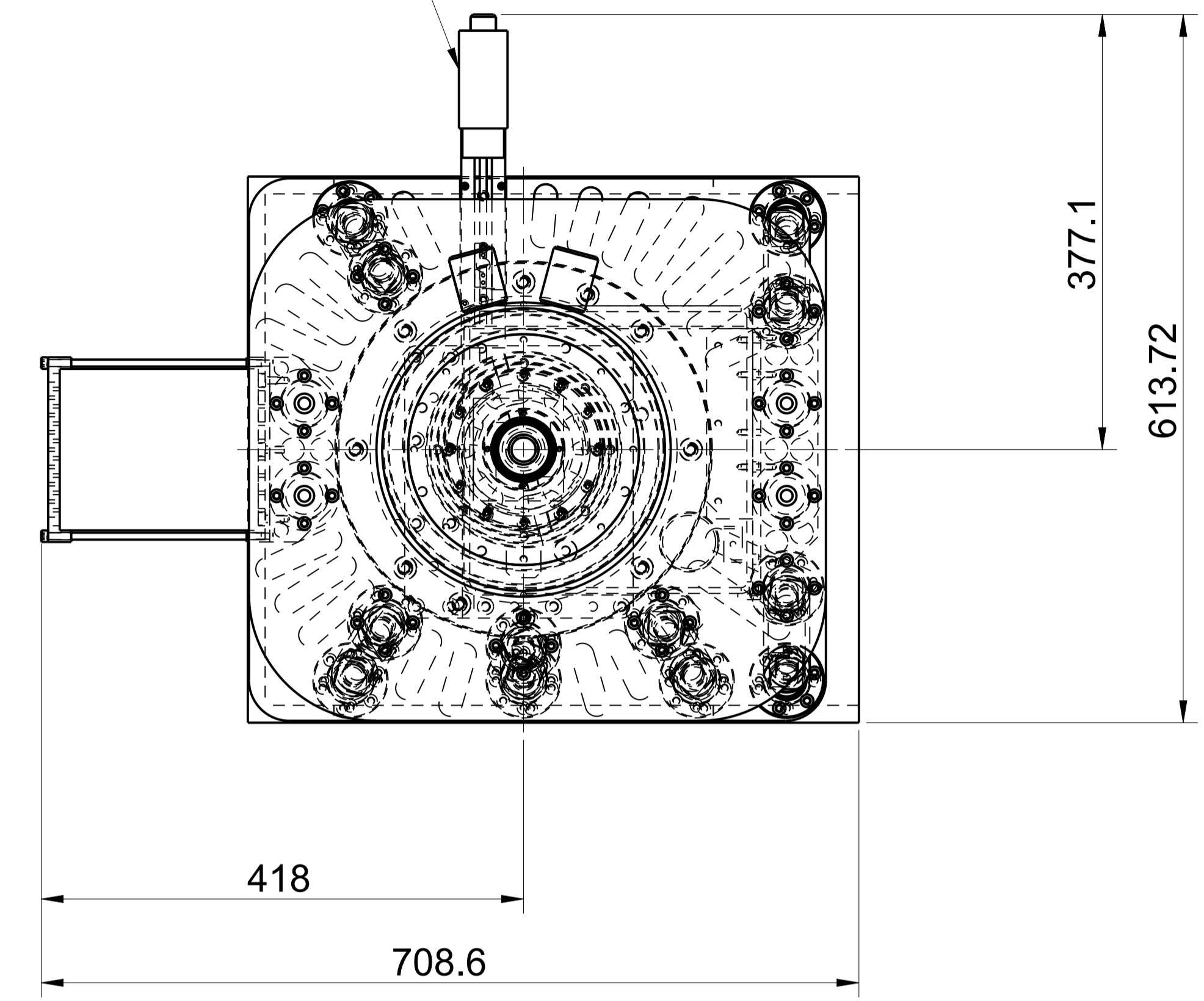

DO NOT SCALE
PROJECTION

EXPLANATION OF NOTES,
SYMBOLS, DIMS: SEE BS 8888

GENERAL NOTES
DIMENSIONS mm
REMOVE ALL BURRS AND SHARP CORNERS
MAXIMUM CHAMFER 0.5 U.S.O
LINEAR DIMENSIONS +/- 0.1 U.S.O
ANGULAR DIMENSIONS +/- 0' 30" U.S.O
SURFACES 3.2 μ m U.S.O

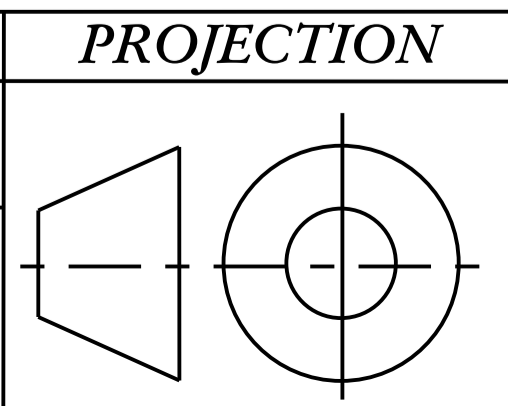

CONFORMS TO BS 8888		ITEM	REQD	DESCRIPTION	MATERIAL
SCALE	DRAWN	DATE	CHECKED	APPROVED	ASSEMBLY #
1:1.25	T.G	18/09/12			COMPONENTS
AREA THAI NATIONAL TELESCOPE "THAILAND"					
DESCRIPTION ARRANGEMENT OF ULTRA-SPEC STRUCTURE DEPICTING COMPONENT POSITIONS & ASSOCIATED WEIGHTS					
THIS DRAWING IS STRICTLY CONFIDENTIAL, NOT FOR THIRD PARTY DISTRIBUTION.					
DRAWING NUMBER					REV
ULT-SPEC-020					A

