

A

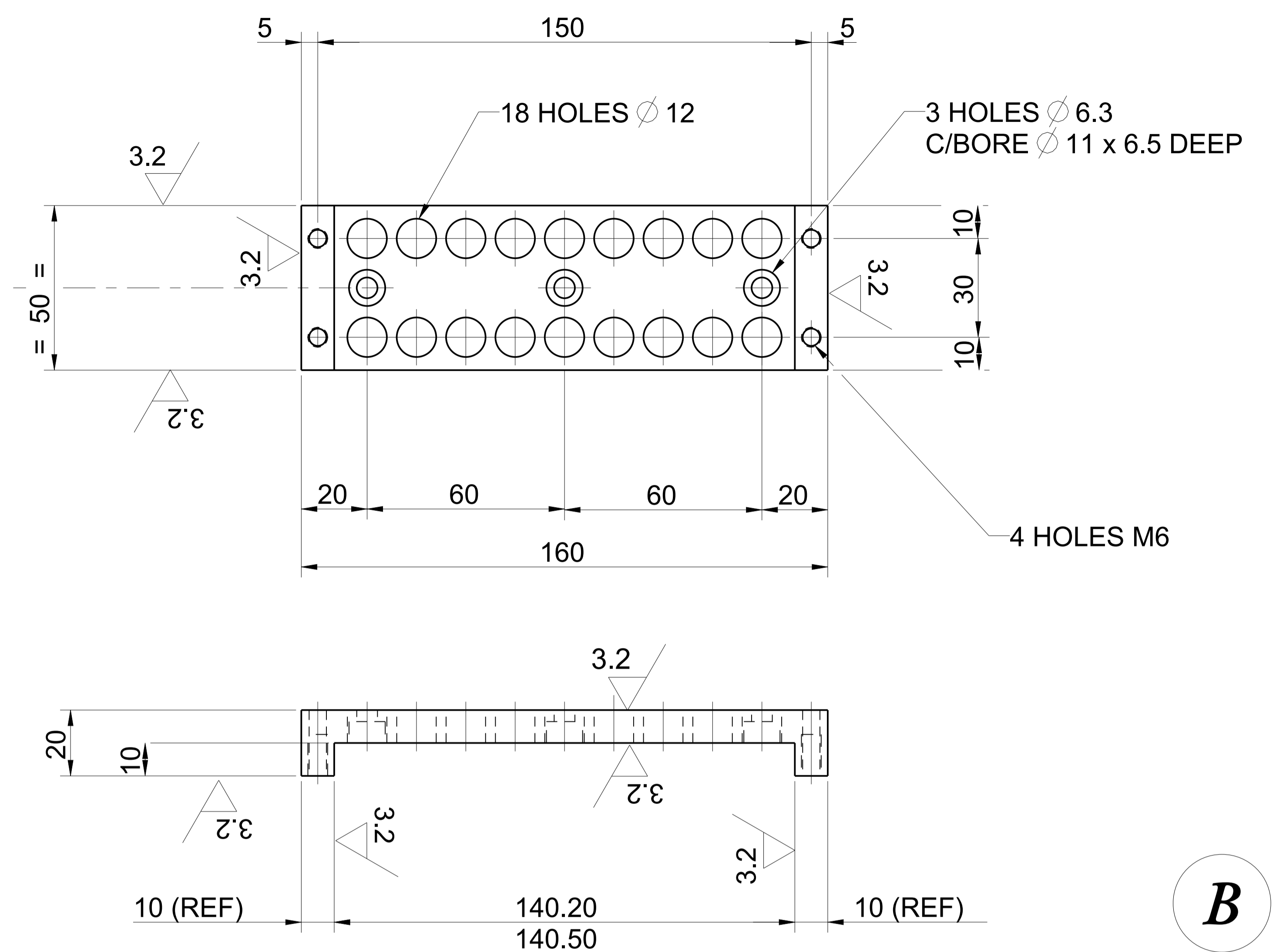

B

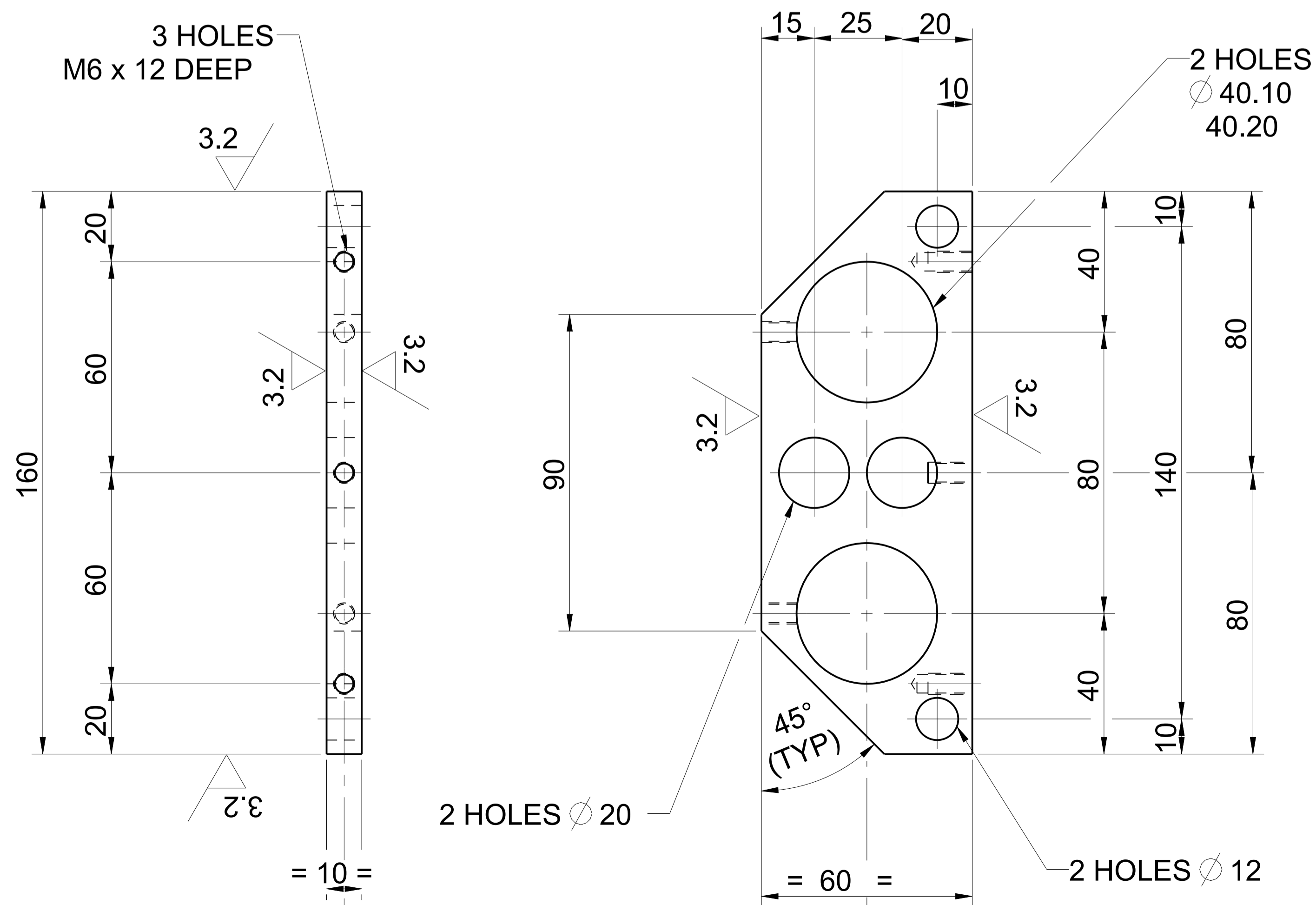

C

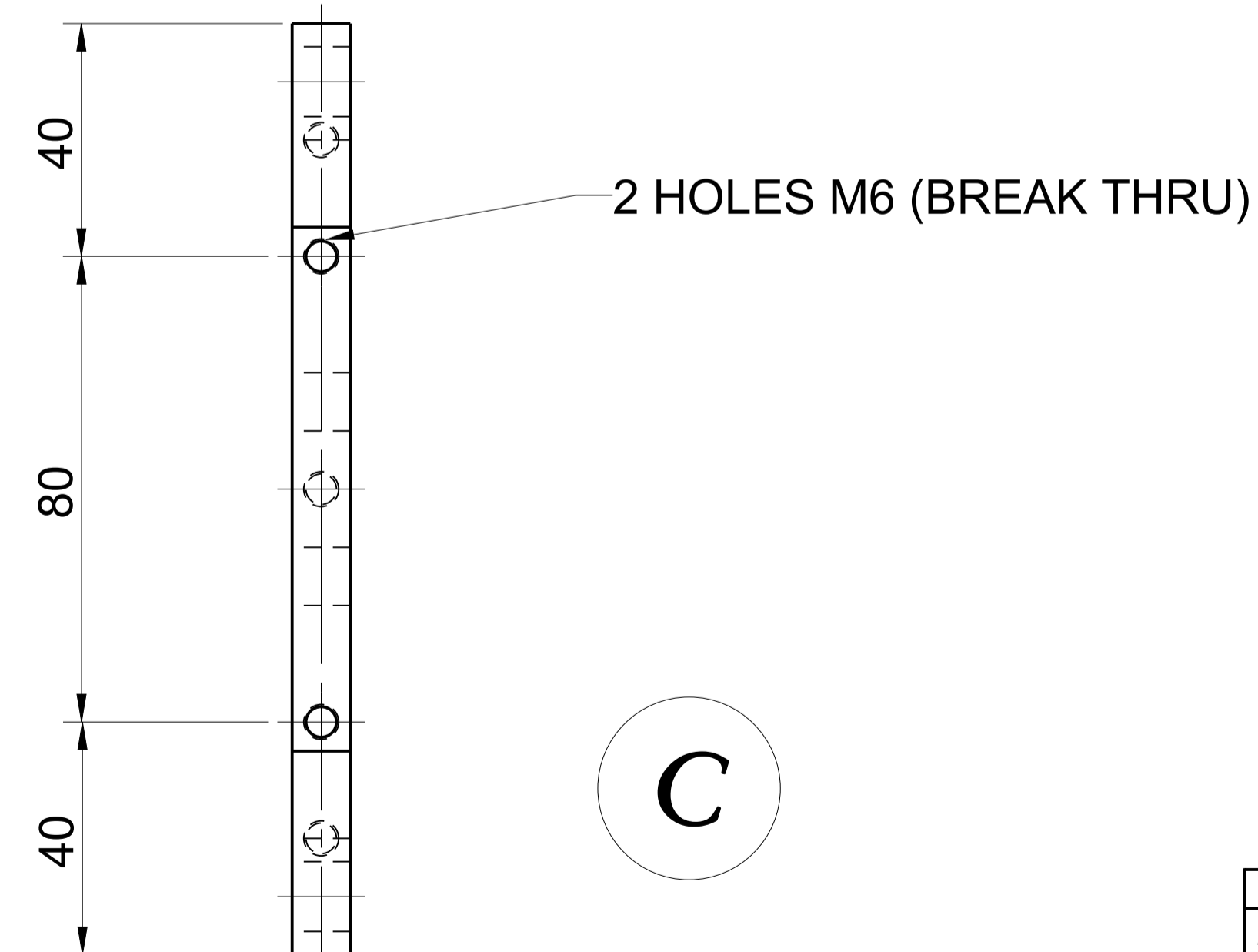

DO NOT SCALE
EXPLANATION OF NOTES, SYMBOLS, DIMS: SEE BS 8888
 GENERAL NOTES
 DIMENSIONS mm
 REMOVE ALL BURRS AND SHARP CORNERS
 MAXIMUM CHAMFER 0.5 U.S.O
 LINEAR DIMENSIONS +/- 0.1 U.S.O
 ANGULAR DIMENSIONS +/- 0' 30" U.S.O
 SURFACES 3.2 *typ* U.S.O

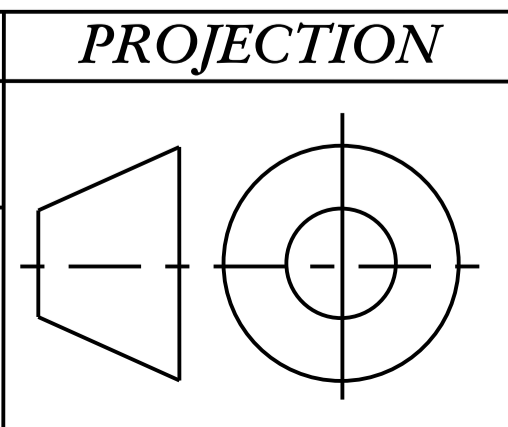

CONFORMS TO BS 8888		ITEM	REQD	DESCRIPTION	MATERIAL
C	2	CCD CLAMP HOLDER			ALUMINIUM GRADE 6061
B	2	CCD BOTTOM CLAMP			ALUMINIUM GRADE 6061
A	2	CCD TOP CLAMP			ALUMINIUM GRADE 6061

SCALE	DRAWN	DATE	CHECKED	APPROVED	ASSEMBLY
1:1	T.G	12/09/12			COMPONENTS #

AREA		THAI NATIONAL TELESCOPE "THAILAND"	
DESCRIPTION		DETAILS OF CCD CONTROLLER TOP AND BOTTOM CLAMP, ALSO CLAMP HOLDER	
THIS DRAWING IS STRICTLY CONFIDENTIAL, NOT FOR THIRD PARTY DISTRIBUTION.			
DRAWING NUMBER		REV	
ULT-SPEC-019		A	

