

1 2 3 4 5 6 7 8 9 10 11 12 13 14 15 16

A  
B  
C  
D  
E  
F  
G  
H  
I  
J

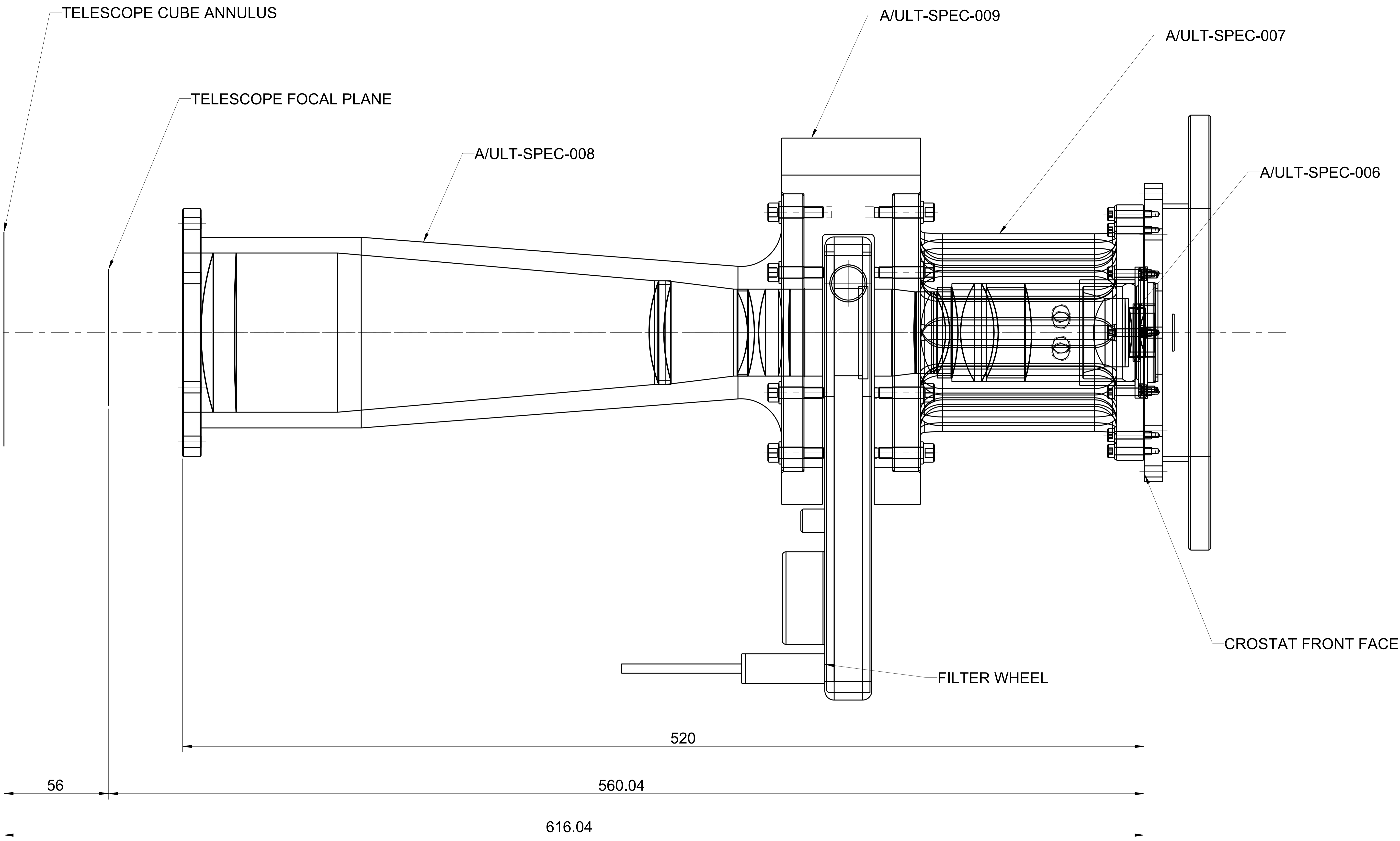

**NOTE!**  
THIS DRAWING TO BE READ IN CONJUNCTION  
WITH DRAWING NUMBER ULT-SPEC-011

**DO NOT SCALE**

**EXPLANATION OF NOTES,  
SYMBOLS, DIMS: SEE BS 8888**

GENERAL NOTES  
DIMENSIONS mm  
REMOVE ALL BURRS AND SHARP CORNERS  
MAXIMUM CHAMFER 0.5 U.S.O  
LINEAR DIMENSIONS +/- 0.1 U.S.O  
ANGULAR DIMENSIONS +/- 0' 30" U.S.O  
SURFACES 3.2 / $\mu$ m U.S.O

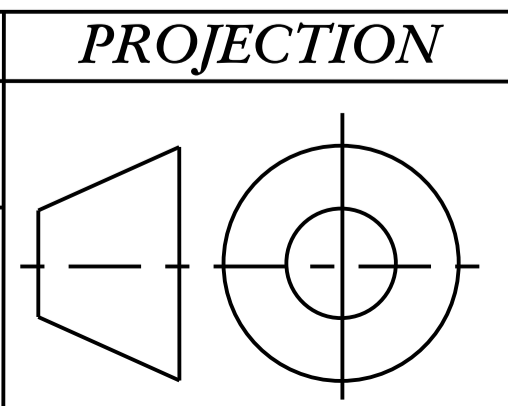

CONFORMS TO BS 8888		ITEM	REQD	DESCRIPTION	MATERIAL
SCALE	DRAWN	DATE	CHECKED	APPROVED	ASSEMBLY #
1:1	T.G	29/06/12			COMPONENTS
AREA		THAI NATIONAL TELESCOPE "THAILAND"			
DESCRIPTION		GENERAL ARRANGEMENT OF THE COMPLETE OPTICS			
THIS DRAWING IS STRICTLY CONFIDENTIAL, NOT FOR THIRD PARTY DISTRIBUTION.					
DRAWING NUMBER		ULT-SPEC-010			REV A

