

NOTE!  
FOR BASIC DIMENSIONS SEE ITEM 'A'

**PROVISIONAL ENQUIRY ONLY  
NOT FOR MANUFACTURE**

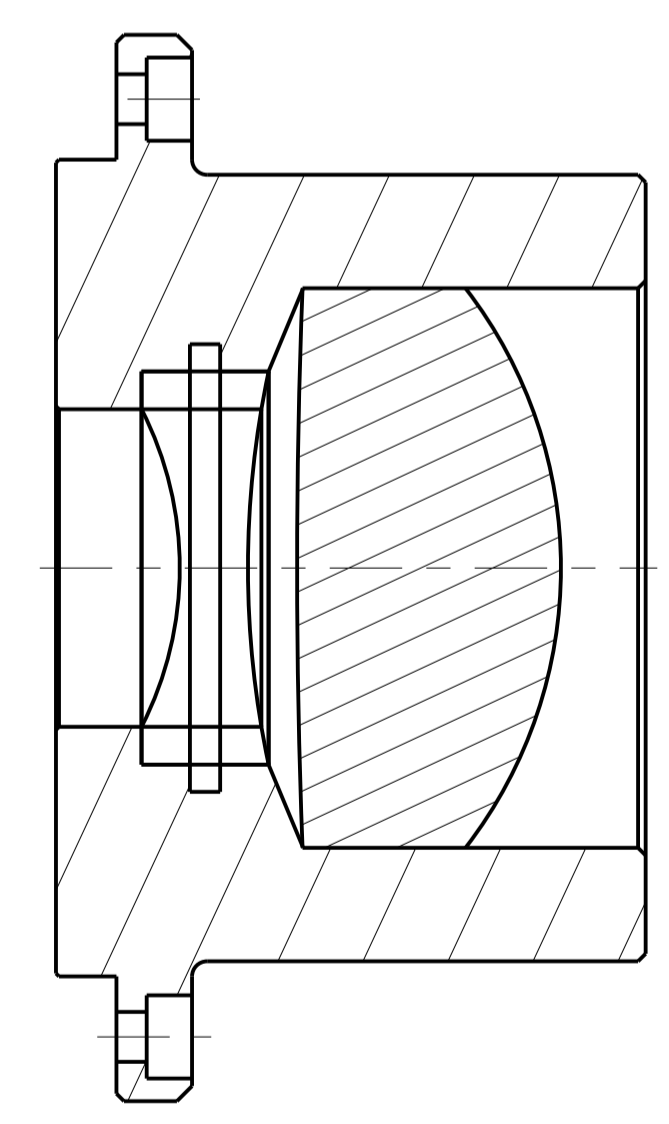

NOTE!  
FOR BASIC DIMENSIONS SEE ITEM 'A'

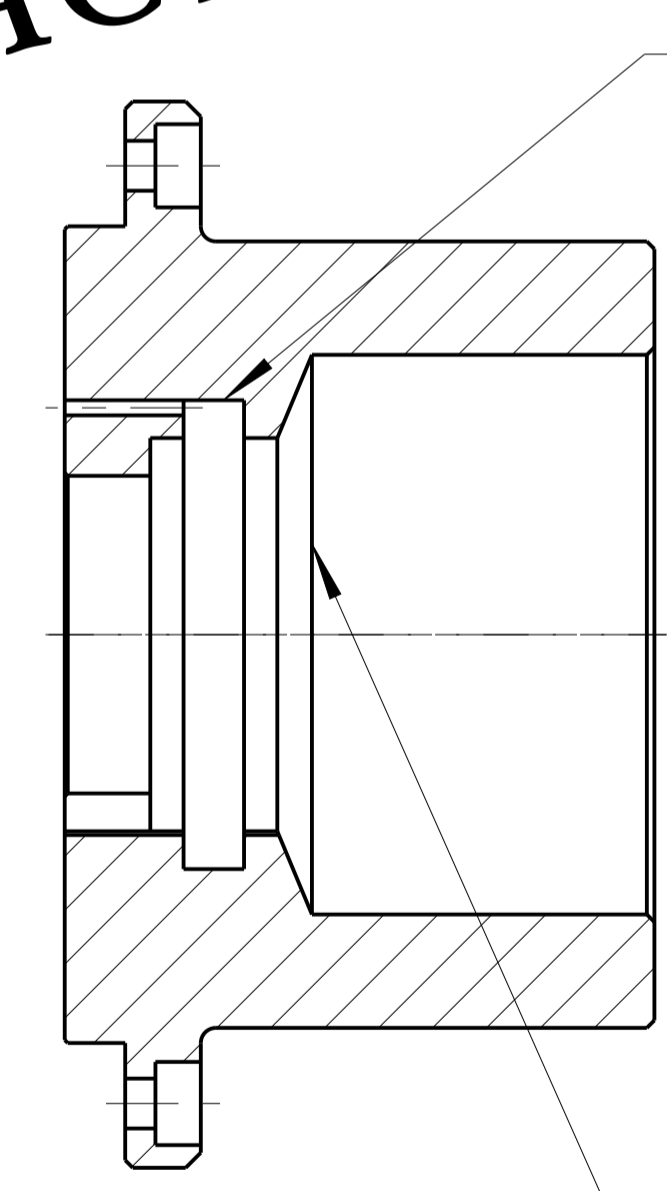

NOTE!  
FOR BASIC DIMENSIONS SEE ITEM 'A'

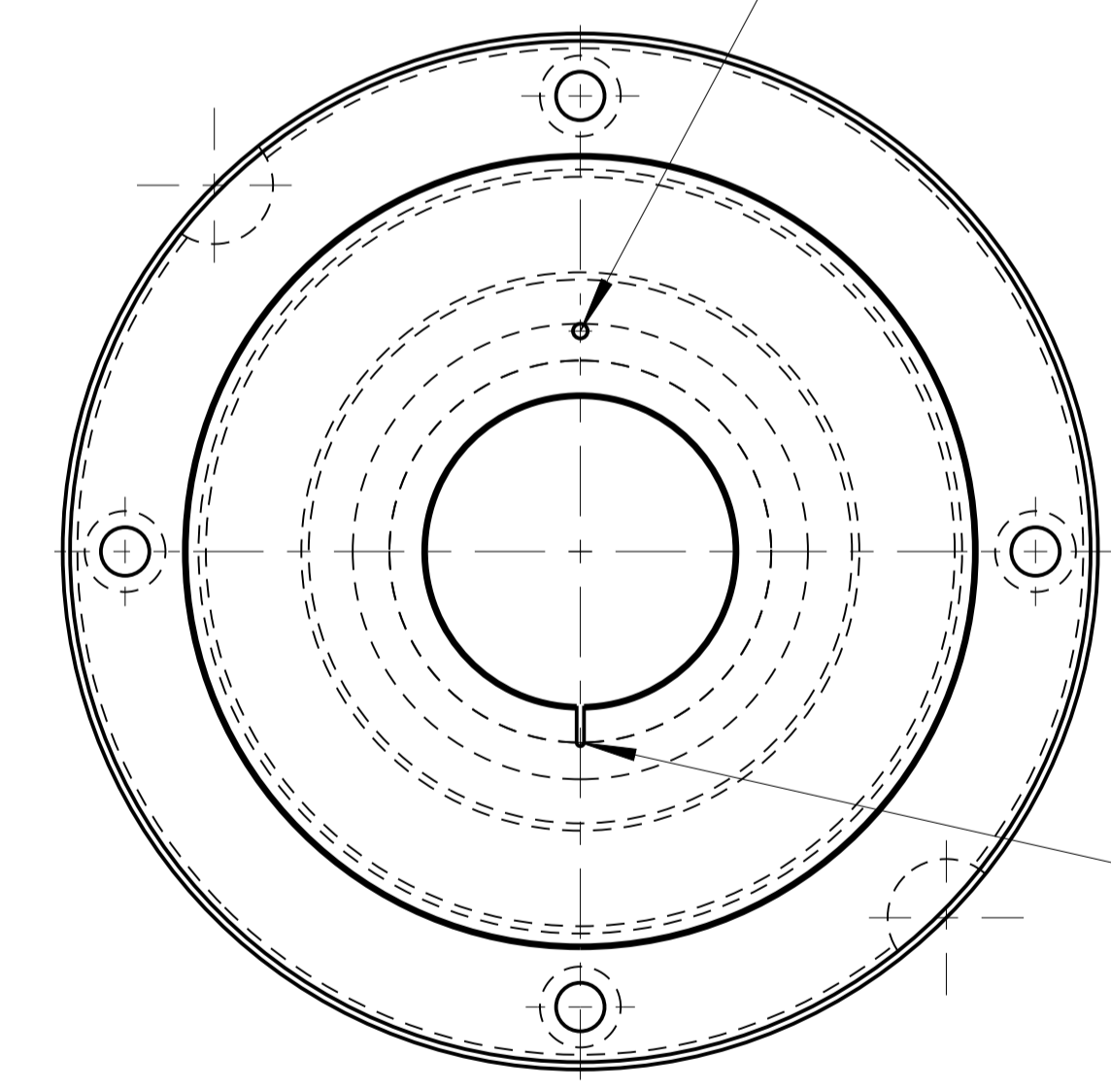

**D**

D	1	LENS BARREL 1 CAMERA GROUP (CONCEPT D)	ALUMINIUM Grade 6061 ?
C	1	LENS BARREL 1 CAMERA GROUP (CONCEPT C)	ALUMINIUM Grade 6061 ?
B	1	LENS BARREL 1 CAMERA GROUP (CONCEPT B)	ALUMINIUM Grade 6061 ?
A	1	LENS BARREL 1 CAMERA GROUP (CONCEPT A)	ALUMINIUM Grade 6061 ?

DO NOT SCALE		PROJECTION	
EXPLANATION OF NOTES, SYMBOLS, DIMS: SEE BS 8888			
GENERAL NOTES DIMENSIONS mm REMOVE ALL BURRS AND SHARP CORNERS MAXIMUM CHAMFER 0.5 U.S.O LINEAR DIMENSIONS +/- 0.1 U.S.O ANGULAR DIMENSIONS +/- 0' 30" U.S.O SURFACES 3.2 $\mu$ m U.S.O			

CONFORMS TO BS 8888	ITEM	REQD	DESCRIPTION	MATERIAL
SCALE	DRAWN	DATE	CHECKED	APPROVED
2:1	T.G	20/04/12		
ASSEMBLY #				
COMPONENTS				

AREA THAI NATIONAL TELESCOPE

DESCRIPTION DETAILS OF LENS BARREL 1 CAMERA GROUP (4 CONCEPTS)

THIS DRAWING IS STRICTLY CONFIDENTIAL.  
NOT FOR THIRD PARTY DISTRIBUTION.

DRAWING NUMBER **ULT-SPEC-004** REV A

